

# Distinctive Characteristics

Sealed construction prevents contact contamination and allows automated soldering and cleaning.

.244" (6.2mm) square body allows compact mounting.

Heat tolerant resin used for actuator and base meets UL flammability rating of 94V-0 and maintains switch reliability through vapor phase and infrared convection reflow soldering.

Dome contact gives crisp tactile feedback to positively indicate circuit transfer and assures high reliability and long life – more than 100,000 operations.

Gull-winged terminals ensure mechanical stability during soldering and simplify solder joint inspection.

Insert molded terminals lock out flux, solvents, and other contaminants.

Packaged in tape-reel or partitioned tray. Tape-reel packaging meets EIA-481-2 Standard.

Coplanarity: all considered surfaces must lie between two parallel planes that are a maximum distance apart of .0059" (0.15mm). (Additional coplanarity details in Terms and Acronyms in the Supplement section.)

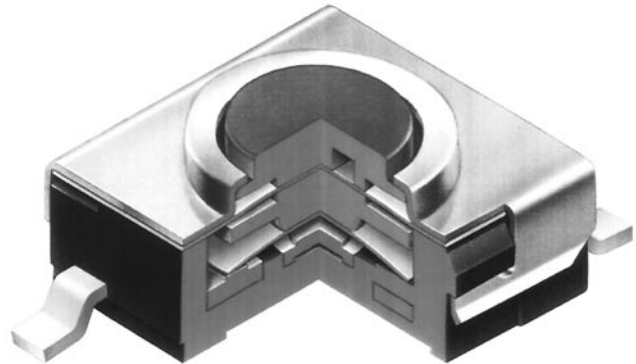

Actual Size

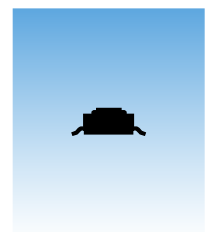

# General Specifications

## Electrical Capacity (Resistive Load)

**Low Level:** 50mA @ 24V DC maximum

## Other Ratings

**Contact Resistance:** 100 milliohms maximum  
**Insulation Resistance:** 100 megohms minimum @ 250V DC  
**Dielectric Strength:** 250V AC minimum between contacts & between contacts & case for 1 minute minimum  
**Mechanical Life:** 100,000 operations minimum  
**Electrical Life:** 100,000 operations minimum  
**Nominal Operating Force:** 1.57N  
**Total Travel:** .010" (.250mm)

## Materials & Finishes

**Actuator:** Glass fiber reinforced polyamide (UL94V-0)  
**Case:** Stainless steel  
**Seal:** Polytetrafluoroethylene  
**Base:** Polyphthalamide (UL94V-0)  
**Movable Contacts:** Beryllium copper with silver plating  
**Stationary Contacts:** Brass with silver plating  
**Terminals:** Brass with silver plating

## Environmental Data

**Operating Temperature Range:** -25°C through +70°C (-13°F through +158°F)  
**Humidity:** 90 ~ 95% humidity for 96 hours @ 40°C (104°F)  
**Vibration:** 10 ~ 55Hz with peak-to-peak amplitude of 1.5mm traversing the frequency range & returning in 1 minute; 3 right angled directions for 2 hours  
**Shock:** 50G (490m/s<sup>2</sup>) acceleration (tested in 6 right angled directions, with 5 shocks in each direction)

## Processing

**Soldering:** Reflow Soldering Recommended. See Profile A in Supplement section.  
 Manual Soldering: See Profile A in Supplement section.  
**Cleaning:** Automated cleaning. See Cleaning Specifications in Supplement section.

## Standards & Certifications

**Flammability Standards:** UL94V-0 actuator & base  
**UL Recognition or CSA Certification:** The CB3 Series tactiles have not been tested for UL recognition or CSA certification. These switches are designed for use in a low-voltage, low-current, logic-level circuit. When used as intended in a logic-level circuit, the results do not produce hazardous energy.

### TYPICAL SWITCH ORDERING EXAMPLE

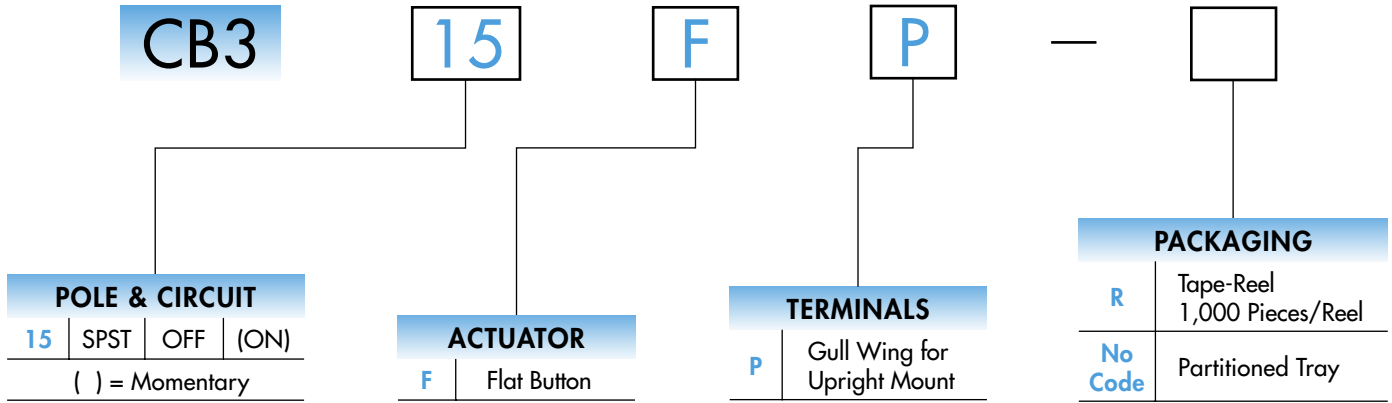

### DESCRIPTION FOR TYPICAL ORDERING EXAMPLE

#### CB315FP

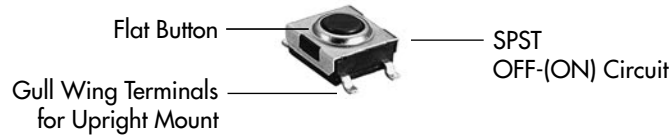

### POLE & CIRCUIT

Pole	Model	Actuator Position ( ) = Momentary		Switch Throw & Schematic	Note: Terminal numbers are not actually on switch.
		Normal	Down		
SP	CB315	OFF	(ON)	SPST 	

### TYPICAL SWITCH DIMENSIONS

#### Single Pole • Single Throw

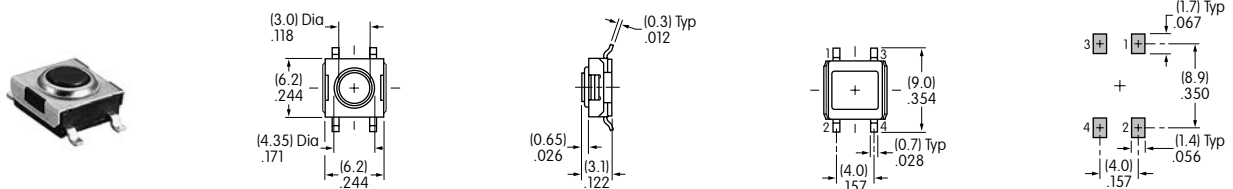

CB315FP

### PACKAGING

**R**

**Tape-Reel** (packaged to EIA-481-2 standard)

Switches must be ordered in 1,000-piece increments when tape-reel packaging is selected.

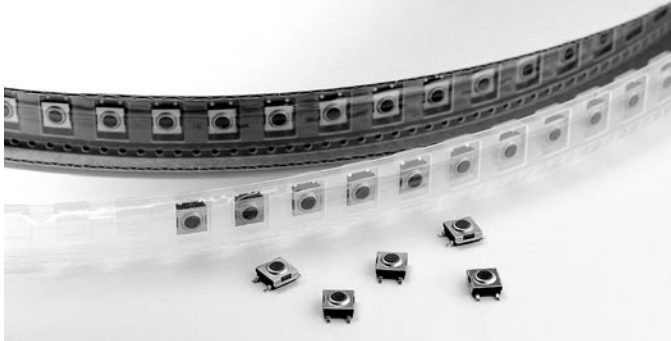

**No Code**

**Partitioned Tray**

If less than 1,000 pieces are ordered, the switches are packaged in a partitioned tray. No code is required.

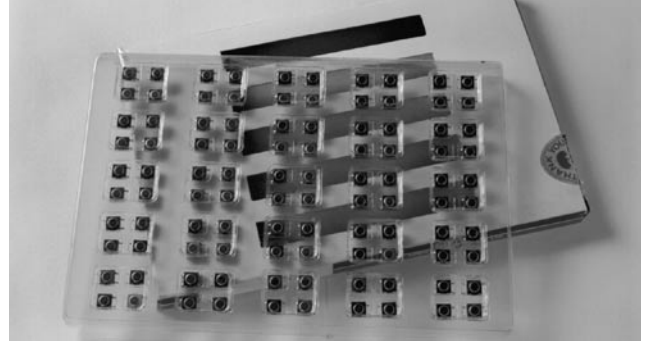

### Tape-Reel Dimensions & Specifications

Each tape-reel of 1,050 pockets contains 1,000 switches

Minimum Leader Length: 16.54" (420mm) Minimum Trailer Length: 7.09" (180mm)

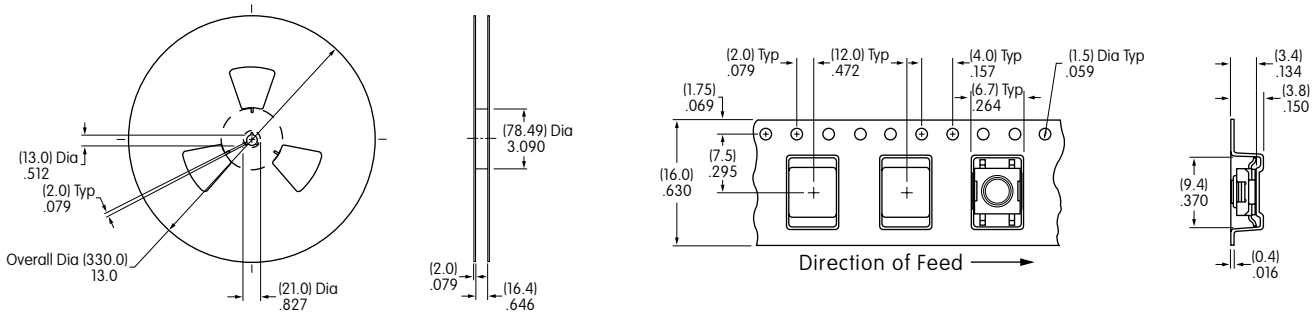

### KEYBOARD MATRIX

#### Common Bus Matrix

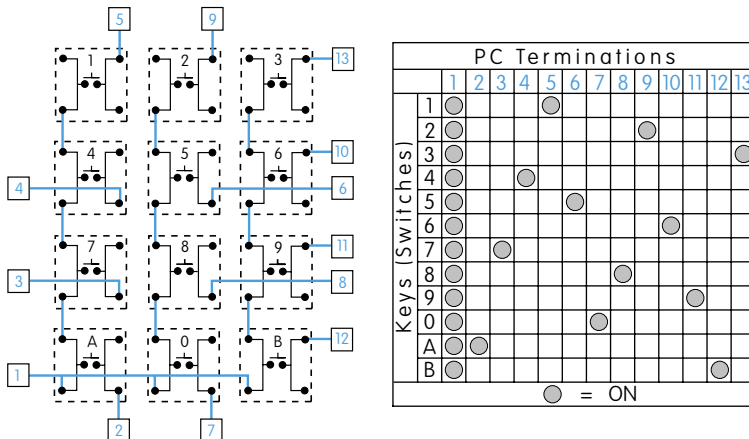

Blue = PCB Trace, Black = Switch Circuit

These single pole, single throw switches can be used in a keyboard matrix and, using strapped terminals, achieve a common bus electrical configuration on a single-sided PC board.

#### X-Y Matrix

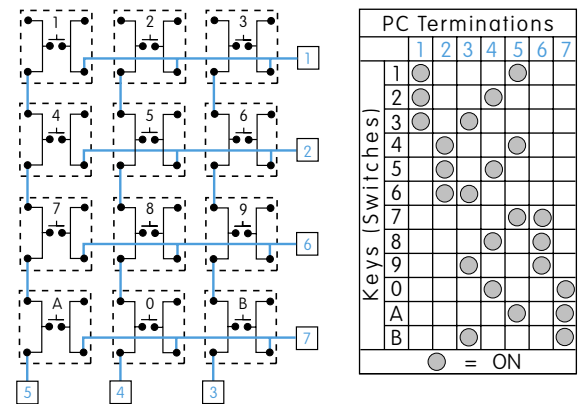

Blue = PCB Trace, Black = Switch Circuit

These single pole, single throw switches can be arranged on a single-sided PC board matrix with strapped terminals to achieve an X-Y type electrical interconnection.